

**Part Number: PT929-18170-02**

**Kit Contents**

Item #	Quantity Req'd.	Description
1	1	Hood & Bumper Dual Stripes
2	1	Roof Dual Stripes
3	1	Trunk Lid Dual Stripes

**Hardware Bag Contents**

Item #	Quantity Req'd.	Description
1		

**Additional Items Required For Installation**

Item #	Quantity Req'd.	Description
1		

**Conflicts**

Paint Protection Film
-----------------------

**Recommended Tools**

<b>Personal &amp; Vehicle Protection</b>	<b>Notes</b>
Blankets	
<b>Special Tools</b>	<b>Notes</b>
Stacked clean cloths	
Squeegee	3M PA-1
Squeegee Sleeve	3M PA-1
Surface Thermometer	Infrared Non-contact
Heat Gun	Master Heat Gun HG-301A or equivalent
<b>Installation Tools</b>	<b>Notes</b>
Tape	
Lint Free Cloth	
Spray Bottle	For wetting agent
<b>Special Chemicals</b>	<b>Notes</b>
VDC Approved Cleaner	
Wetting Agent Note: Solution depends upon ambient temperature of the part and the vehicle surface. If it is difficult to remove bubbles with a squeegee, add one more ml. of shampoo.	Johnson's Baby Shampoo mixed in one liter of water: At 65°F add 2 ml. shampoo At 70°F add 3 ml. shampoo At 80°F add 3.5 ml. shampoo At 90°F add 4 ml. shampoo

**General Applicability**

2017 86 Special Edition
-------------------------

**Recommended Sequence of Application**

Item #	Accessory
1	
2	
3	

\*Mandatory

**Vehicle Service Parts** (may be required for reassembly)

Item #	Quantity Req'd.	Description
1		
2		
3		

**Legend**

 **STOP:** Damage to the vehicle may occur. Do not proceed until process has been complied with.

 **OPERATOR SAFETY:** Use caution to avoid risk of injury.

 **CAUTION:** A process that must be carefully observed in order to reduce the risk of damage to the accessory/vehicle and to ensure a quality installation.

 **TOOLS & EQUIPMENT:** Used in Figures calls out the specific tools and equipment recommended for this process.

 **REVISION MARK:** This mark highlights a change in installation with respect to previous issue.

 **SAFETY TORQUE:** This mark indicates that torque is related to safety.

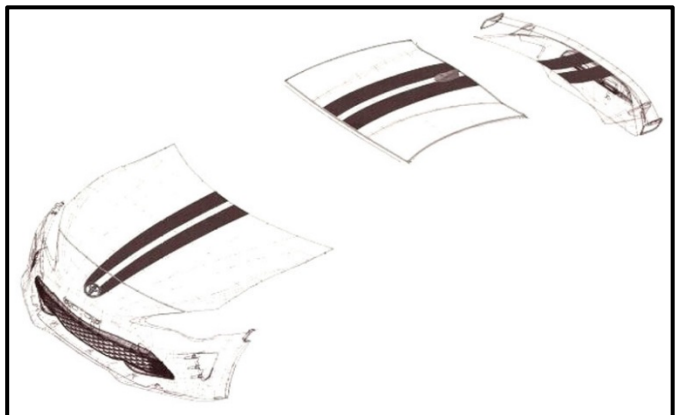

Care must be taken when installing this accessory to ensure damage does not occur to the vehicle. The installation of this accessory should follow approved guidelines to ensure a quality installation.

These guidelines can be found in the "Accessory Installation Practices" document.

This document covers such items as:-

- Vehicle Protection (use of covers and blankets, cleaning chemicals, etc.).
- Safety (eye protection, rechecking torque procedure, etc.).
- Vehicle Disassembly/Reassembly (panel removal, part storage, etc.).
- Electrical Component Disassembly/Reassembly (battery disconnection, connector removal, etc.).

Please see your Toyota dealer for a copy of this document.

**1. Prepare for the Installation.**

 (a) The parts and vehicle surface temperature must be between 18°C (65°F) and 32°C (90°F) at the time of installation.

 (b) Place a protective blanket on both fenders.

 (c) Dry fit all graphics prior to installation.

**2. Clean the Hood Surface.**

- (a) Remove any wrap guard from the hood (if applicable).
- (b) Use VDC approved cleaner or equivalent to clean the entire surface of the hood (Fig. 2-1).
- (c) Use a clean, dry, lint-free cloth to dry the installation area.
- (d) Follow with a lint free cloth to remove any remaining dust or lint.

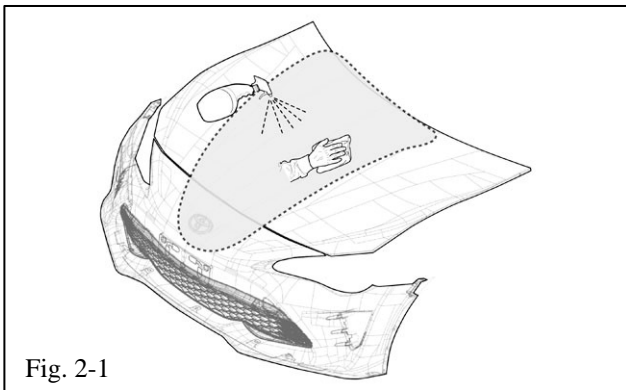
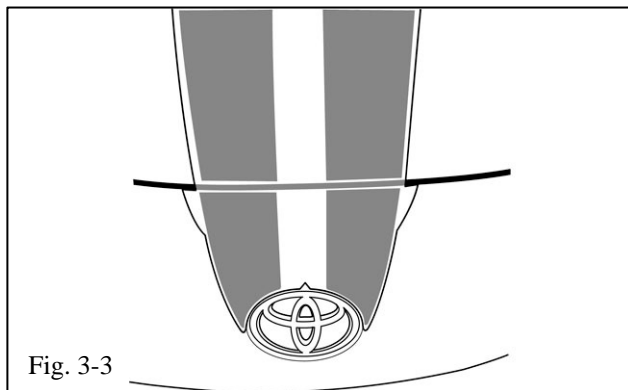
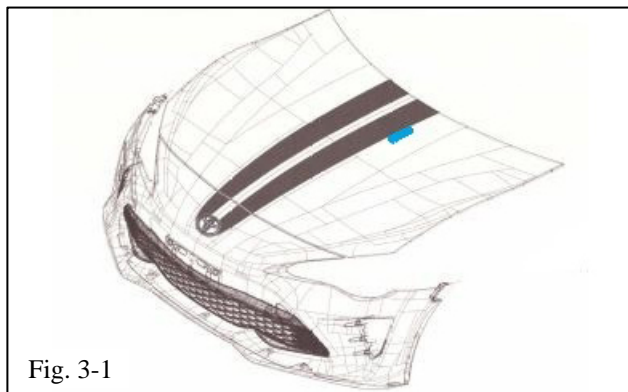
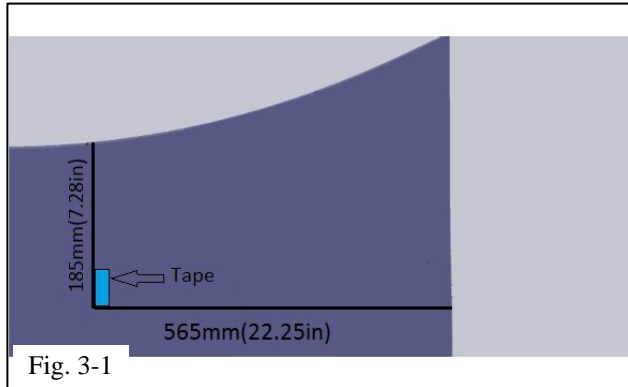

Fig. 2-1



### 3. Install the Hood & Bumper Stripes.

(a) Measure 185 mm from the top of the hood and 565mm from the driver's side edge of the hood and place tape for edge of graphic alignment (Fig. 3-1).

**!** (b) Spray the water and soap mixture on the hood and front bumper section of the vehicle.

(c) Remove the backing liner from the dual stripes and spray the exposed part with the water and soap mixture.

**!** (d) Align the rear edge of the hood stripe to the line with the sheet metal. (V-notch at rear edge of premask can be aligned off rib in dash). Align the left edge of the premask to the tape and the front edge around the hood emblem (Fig. 3-2).

(e) Ensure the v-notch is centered above the emblem. The graphic should be even from side to side around the emblem (Fig. 3-3).

**!** (f) Visually position the graphic so that the gap between the hood and the bumper are equal and the v-notch is centered. Verify that the graphic has not moved over the edge at the windshield. If the gaps are even move to step 3(h); if gaps are uneven, proceed to 3(g).

(g) Spray the premask surface with the water and soap solution.

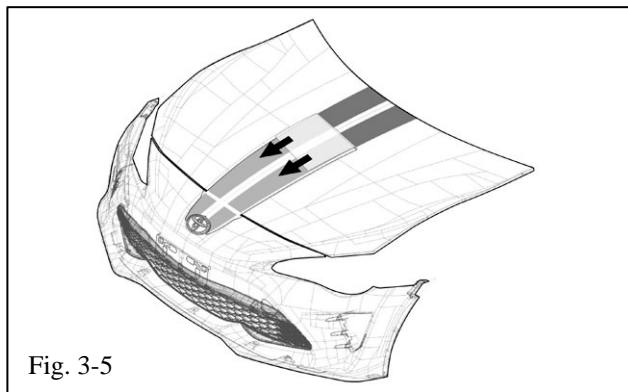
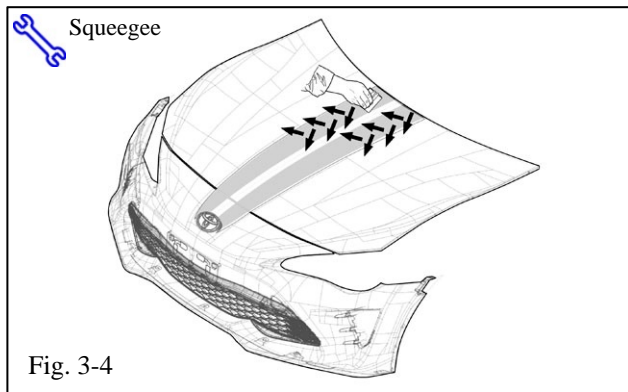

**STOP** (h) Starting at the emblem on the hood, install the stripes onto the hood using the squeegee to adhere the part to the vehicle and remove any air bubbles (Fig. 3-4).

**STOP** (i) Peel back the top layer of the part at the rear edge of the hood to remove the premask from the graphic. Peel the premask back at a 180° angle (Fig. 3-5).

**!** (j) Continue to remove the premask in the bumper section, taking care to separate the premask and the stripe material.

(k) Once all of the premask has been removed, use the squeegee or felt block to remove any remaining bubbles.

#### 4. Install the Roof Stripes.

**STOP** (a) Step stool may be required for reach. Protect vehicle and do not step in/on vehicle to install.

**!** (b) At the drivers side front of the roof, measure 420mm from the edge of the roof towards the center of the vehicle and place a piece of tape on the roof at that location as shown in Fig. 4-1.

**!** (c) Spray the roof surface with the soap and water solution.

(d) Remove the backing liner from the dual stripes and spray the exposed part with the water and soap mixture.

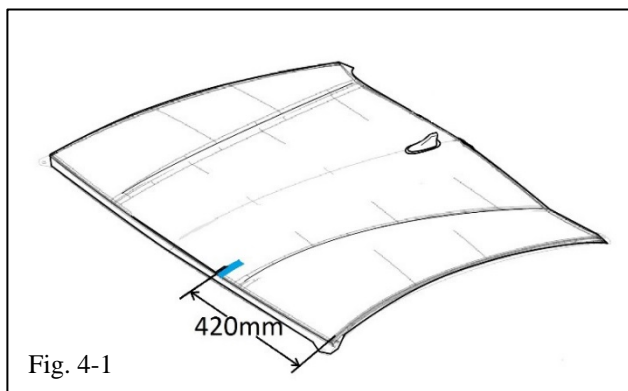

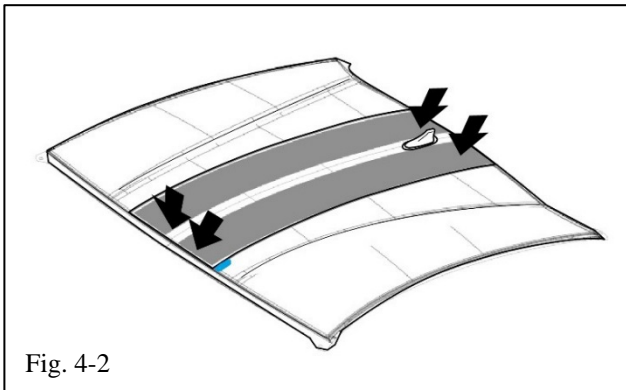



(e) Place the graphic over the antenna to align the rear of the part (Fig. 4-2).

 (f) Align the left edge of the premask with the tape to align the front of the part (Fig. 4-2).

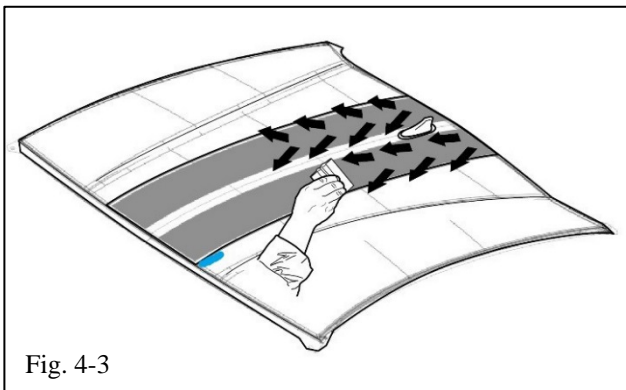
(g) Spray the graphic with the soap and water solution.



 (h) Verify v-notch alignment with satellite antenna from the rear of the vehicle. Starting at the rear of the roof, install the stripes onto the roof using the squeegee to adhere the part to the vehicle and remove any air bubbles (Fig. 4-3).

(i) Continue to install the stripes using the squeegee towards the front of the vehicle (Fig. 4-3).

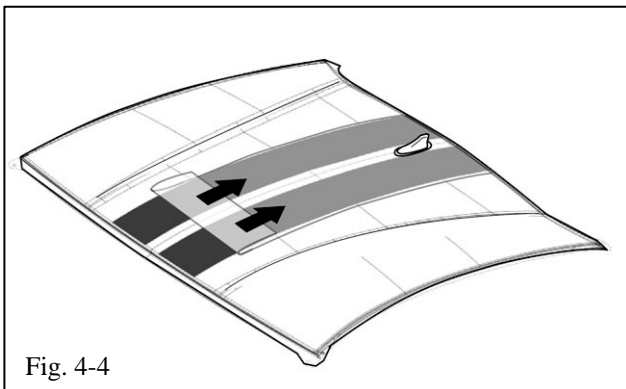

 (j) Remove the tape and peel back the top layer of the part at the front edge of the roof to remove the premask from the graphic. Peel the premask back at a 180° angle (Fig. 4-4).

(k) Once all of the premask has been removed, use the squeegee or felt block to remove any remaining bubbles.

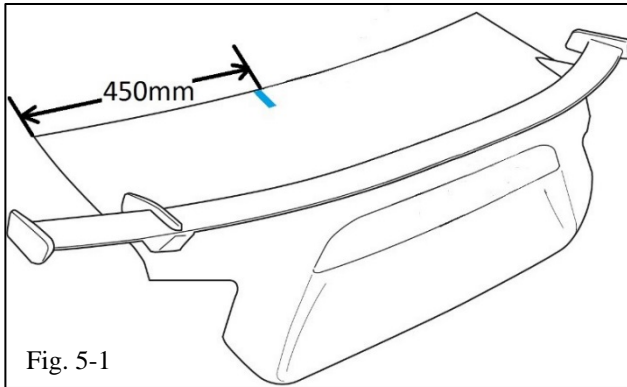

**5. Install the Trunk Stripes.**

(a) Measure 450mm from the driver's side front edge of the trunk towards the center and place a piece of tape on the trunk at the location as shown (Fig. 5-1).

(b) Place the clean cloths between the spoiler and the trunk on either side of the stripe area to raise the spoiler up from the trunk.

 (c) Spray the trunk surface with the soap and water solution.

(d) Remove the backing liner from the dual stripes and spray the exposed part with the soap and water mixture.

 (e) Align the left edge of the premask with the tape edge and the front edge of the tape to the sheet metal (Fig. 5-2).

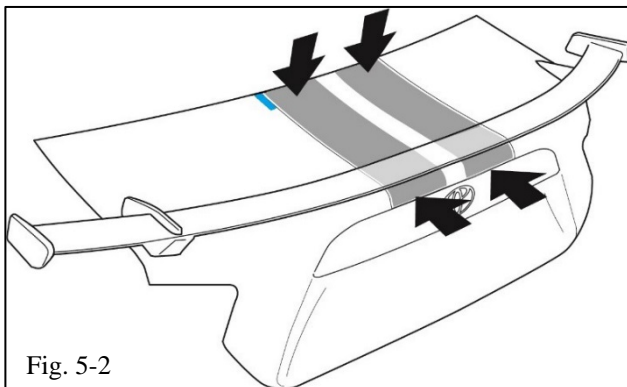

 (f) Center the V-notch over the vehicle emblem to align the rear edge of the part (Fig. 5-3).

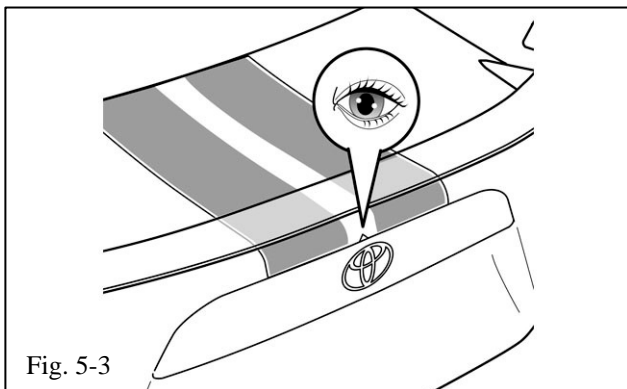

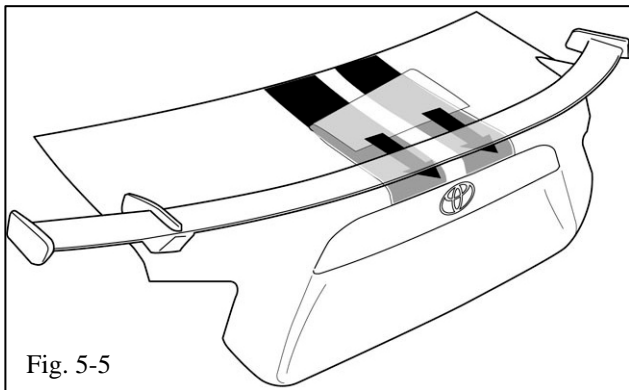
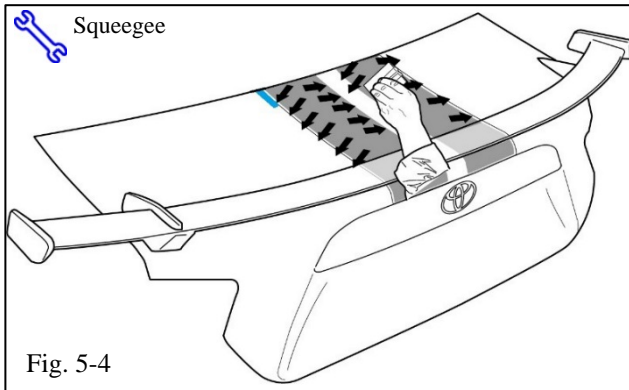

- (g) Starting at the front of the trunk, install the stripes onto the trunk, using the squeegee to adhere the part to the vehicle and remove any air bubbles (Fig. 5-4).
- (h) Continue to install the stripes using the squeegee towards the rear of the vehicle, under the rear spoiler and onto the back surface (Fig. 5-4).

-  (i) Remove the tape and peel back the top layer of the part at the front edge of the trunk to remove the premask from the graphic. Peel the premask back at a 180° angle (Fig. 5-5).
- (j) Once all of the premask has been removed, use the squeegee or felt block to remove any remaining bubbles.
- (k) Remove the cloths from between the trunk and the spoiler.

## 6. Perform a Final Inspection.

- (a) Check for loose edges, wrinkles, bubbles and proper alignment. To remove any bubbles, use a felt block or soft cloth and gently rub until the bubble is removed.

Checklist - these points **MUST** be checked to ensure a quality installation.

Check:

Look For:

Accessory Function Checks

Appearance

Check for loose edges, wrinkles, bubbles and proper alignment.

Gap Ranges:

- Roof Gaps: 4-6mm
- All others: 0-4mm (except hood and bumper and around emblems; must be even gaps within specification)

Vehicle Function Checks

Vehicle Appearance Check

After accessory installation and removal of protective cover(s), perform a visual inspection.

Ensure no damage (including scuffs and scratches) was caused during the installation process.

(For PPO installations, refer to TMS Accessory Quality Shipping Standard.)